

Potain Igo 50

Product Guide

Features

- 4000 kg (8818 lb) maximum capacity
- 1100 kg (2425 lb) capacity at 131 ft (40 m)
- 40 m (131 ft) maximum operating hook radius
- 33,8 m (111 ft) maximum hook height with jib set at 20°
- 23,2 m (76 ft) maximum hook height with jib horizontal



Features



Efficiency and reliability

The Igo 50 has a simple and quick set up. While onsite, the crane works quietly, reducing interruption to the surrounding area.

Optional cab

Optional fixed height cab and access ladder allows operator to view the job site from a more advantageous position.



Variable frequency drives

Variable frequency drives provide a lower initial current rush and progressive speed change which can be supported by a smaller generator set than comparable cranes.



North American Highway Axle

Simplify road transport with the North American Highway Axle and adaptation kit 202. Multiple pin positions for optimal weight distribution, DOT compliance and an optional attachable 3rd axle make this an ideal solution for your transportation needs.

Contents

Specifications	4
Transport	5
Dimensions	7
Load charts	8
Crane profile	9
Mechanisms	10
Metric dimensions	11
Metric load charts	12
Metric crane profile	13
Metric mechanisms	14
Symbols glossary	15

Specifications



Jib

40 m (131 ft) radius standard bi-folding offsettable lattice jib. Removable jib extensions can allow additional horizontal jib operating radii of 28 m (92 ft) or 36 m (118 ft). Two (2) tie bar lines with adjustable lengths allow jib to be offset 8° and 20°. Folds to 14 m (46 ft) radius or 29,6 m (97 ft) radius. Two (2) erecting speeds controlled from the remote, opening and aligning are carried out automatically by two (2) hydraulic cylinders.



Mast

Galvanized folding mast with hydraulic cylinder for erection. Two (2) erecting speeds controlled from the remote. No locking necessary. 360° rotation possible during erection.



Chassis

Outriggers swing and lock into position. 4,5 m (14.8 ft) square outrigger spread with 2,5 m (8.2 ft) slewing radius. Level bubble integrated into the chassis. Outrigger pads are stowed on the crane during transport (540 x 410 mm [21 in x 16 in]). *Optional outrigger pads available at heights of 200 mm (7.9 in) and 400 mm (15.7 in).



*Ballast

5640 kg (12,434 lb) concrete ballast standard. Crane with standard ballast is able to be transported on several *axle sets. *Additional 22 800 kg (50,268 lb) concrete ballast optional.



Optional hydraulic ballasting derrick

Uses the hoisting winch to ballast the crane or dismantle/attach *fifth-wheel. Stows alongside the jib during transport.



Electrical requirement

480 volt, 60 Hz measured at the turntable. Earth rod and electric cable stowed on the crane during transport.



Reeving

SM/DM block for 2 or 4-part line. One pin removal to change between SM and DM. Pure SM1 (section of hook block removed) is possible with gain of 100 kg (220 lb) lifting capacity.



Controls

Wireless remote control provides information to the operator about **wind speed, radius, hook height, load, and moment. Lights and buzzers alert the operator when nearing limits of operation.

Auxiliary remote attached by umbilical cord ensures continual operation in case of battery or other malfunction of the wireless remote control.



*Optional Anemometer

Electronic wind speed meter to alert the operator of wind speed conditions. Provides selective display on the radio remote. Maximum in service wind speed is 72 km/h (45 mph) and maximum out of service wind speed is 150 km/h (93 mph).



Swing

RVF 51 Optima+ slewing mechanism with maximum swing speed of 0.8 RPM. Progressive control of speed with counter-slewing possible, anti-load swinging system makes aligning the load and jib easier. Multiple RPM speeds possible depending upon parameter selected.



Hoist

15 LVF 10 Optima: 15 HP variable frequency hoist with 1t (1.1 US t) line pull. 3 notch, progressive speed change according to the accelerating or decelerating ramps. Optima allows the hoist to adapt its speed to the weight of the load.



Trolley

3 DVF 5: 3 HP variable frequency hoist with 500 kg (1102 lb) line pull. 2 notch winch, progressive speed change according to acceleration or deceleration ramps controlled by the frequency converter.



Hydraulic equipment

Four (4) cylinders and two (2) pumps linked to solenoid valves. Two (2) cylinders for unfolding the jib, one (1) for slewing the derrick, and one (1) for raising the mast.



*Optional transport axle sets

Axle sets are available for both jobsite and highway applications. Jobsite axles are rated at either 10 kph (6 mph) or 25 kph (15.5 mph); highway axle set is rated at 80 kph (50 mph).

*Optional equipment

- * STANDARD NORTH AMERICAN SPECIFICATION: includes hydraulic ballasting derrick, high sole plates, Dialog Wind, 12 concrete counterweight slabs, pre-equipment for interference system and Top Zone.
- * High sole plates
- * Fixed height cab and access ladder
- * Transport axles and kits
- * Top Zone
- * Top Tracing
- * Dialog Wind

DJ100 / S120 10 km/h (6 mph)

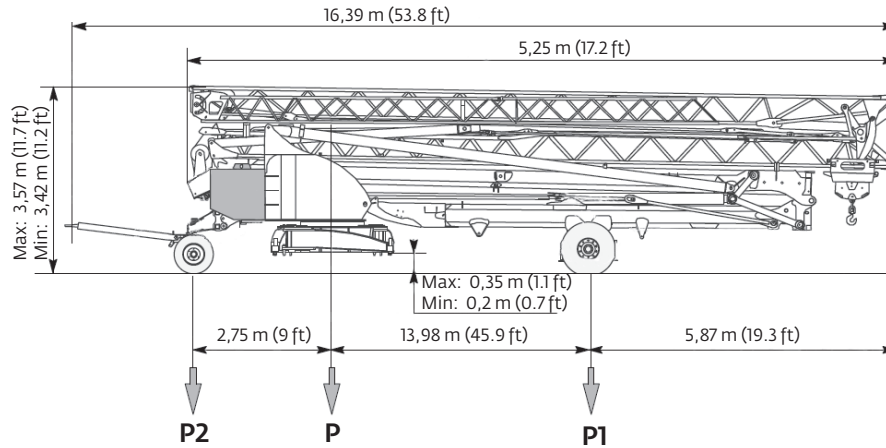

SL122 / J215M 80 km/h (50 mph)

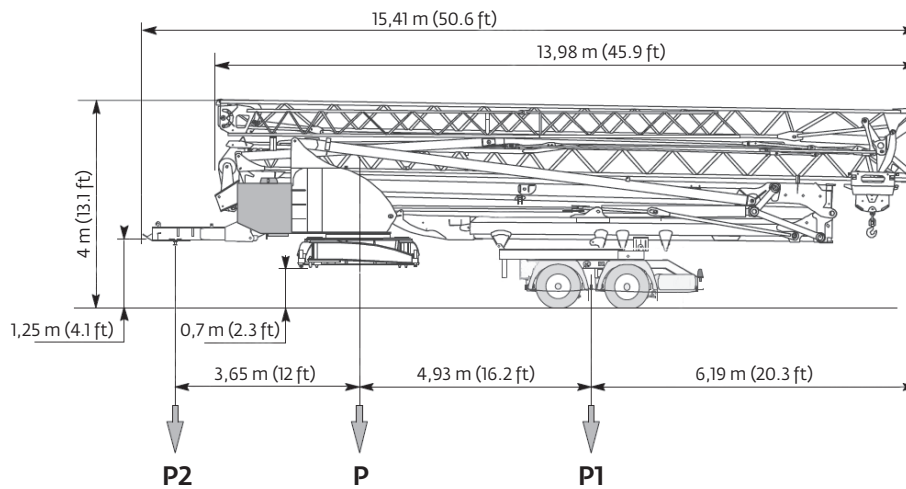

NOTE: Dimensions and weights may vary due to manufacturing tolerances.

Transport

North American Highway Axle

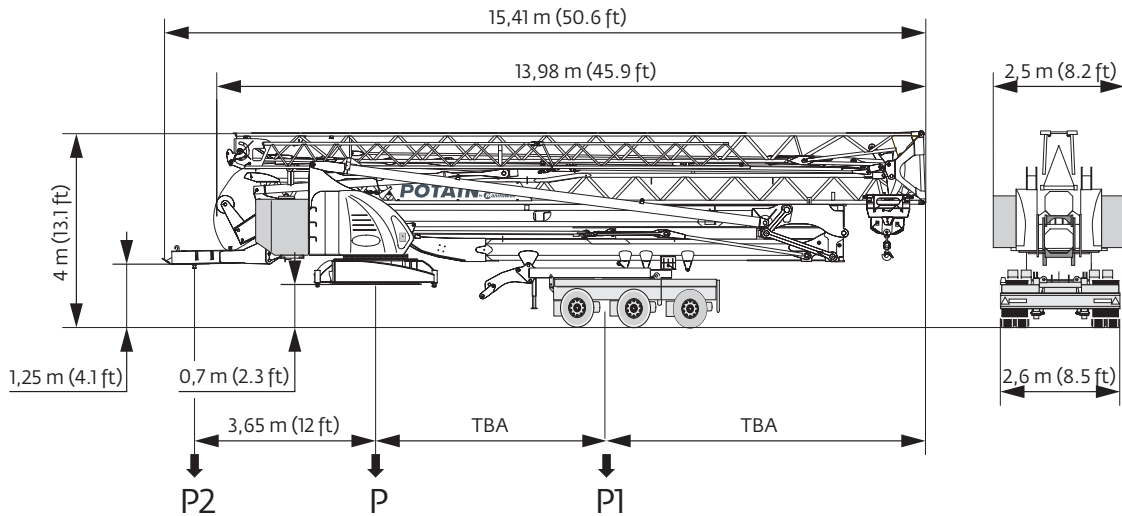

*Other axle sets are available.

Chassis data (in transport position)

	DJ100/S120 25 kph (15.5 mph)		SL122/J215M 80 kph (50 mph)		North American Highway Axle	
	meters	feet	meters	feet	meters	feet
Overall length	16,39	53.8	15,41	50.6	15,41	50.6
Overall height	Max: 3,57 Min: 3,42	Max: 11.7 Min: 11.2	4	13.1	4	13.1
Overall width	2,5	8.2	2,5	8.2	2,6	8.2
Overhang	5,87	19.3	6,19	20.3	TBA	TBA

Weights

Crane weight less counterweight	14 760 kg	32,540 lb
Counterweight for operation	28 440 kg	62,700 lb
Crane with counterweight	43 240 kg	95,328 lb

Crane with transport equipment

	DJ100/S120 25 kph (15.5 mph)		SL122/J215M 80 kph (50 mph)		North American Highway Axle	
	kilograms	pounds	kilograms	pounds	kilograms	pounds
In transport with minimal counterweight:						
Gross (P)	21 655	47,741	23 650	52,139	TBA	TBA
Rear (P1)	11 725	25,849	15 400	33,951	TBA	TBA
Front (P2)	9930	21,892	8250	18,188	TBA	TBA
Counterweight in transport (2 blocks):	5640	12,434	5640	12,434	TBA	TBA

NOTE: Dimensions and weights may vary due to manufacturing tolerances.

Dimensions

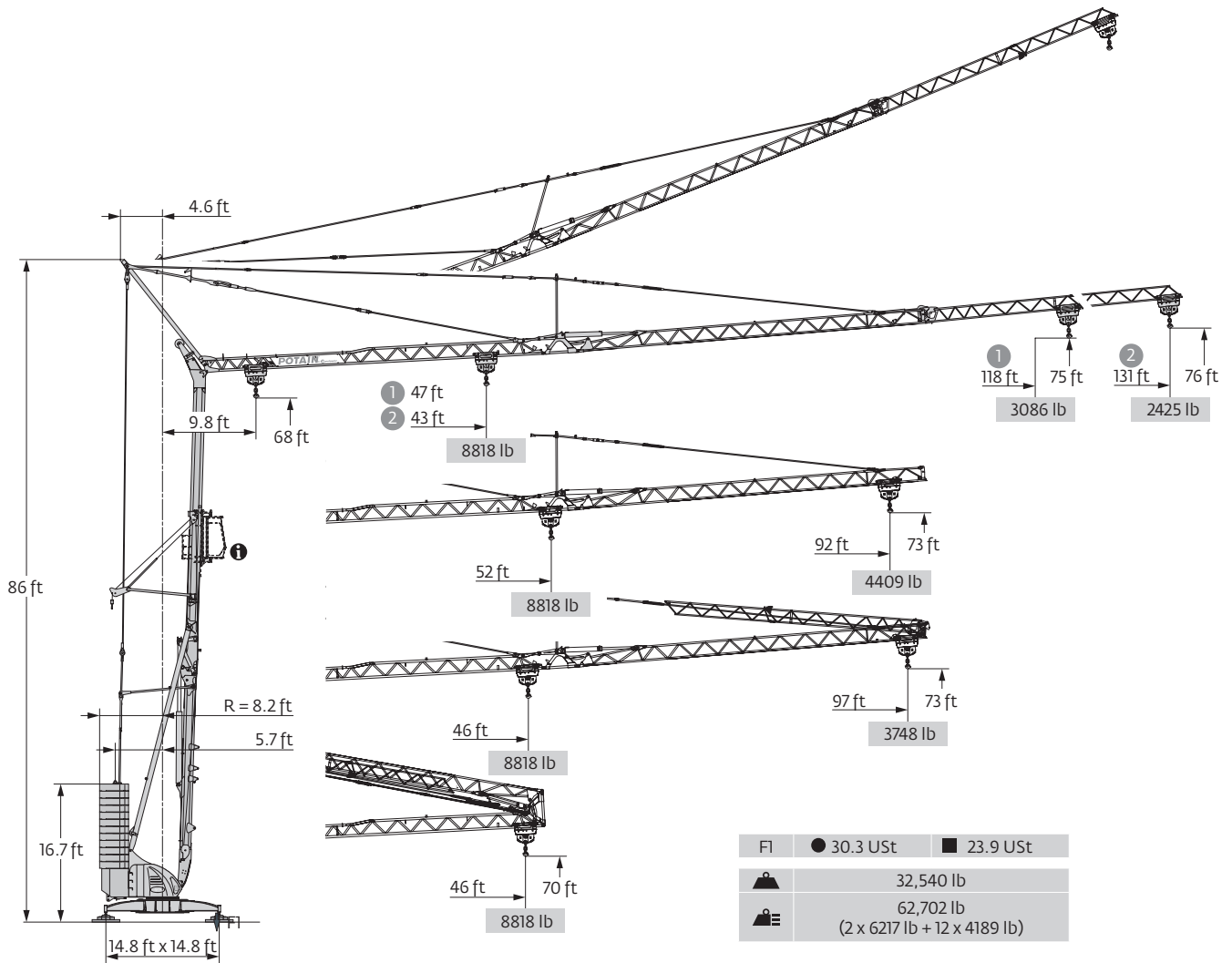

Load charts

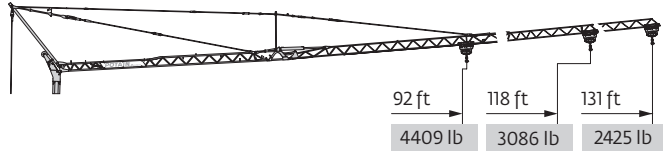
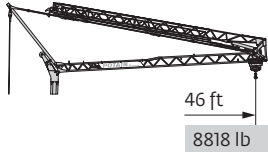

131 ft	10	▶	46	ft
▲▲▲▲			8818	lb
▲▲▲			4409	lb
▲▲			4409	lb
118 ft	10	▶	46	ft
▲▲▲▲			8818	lb
▲▲▲			4409	lb
▲▲			4409	lb
92 ft	10	▶	46	ft
▲▲▲▲			8818	lb
▲▲▲			4409	lb
▲▲			4409	lb

10	▶	43	46	49	52	56	59	62	66	75	79	82	89	98	105	115	121	131	ft	
▲▲▲▲			8818	8080	7419	6845	6360	5930	5556	5214	4409	4134	3968	3616	3175	2932	2612	2436	2205	lb
▲▲▲											4409	4134	3968	3616	3175	2932	2612	2436	2205	lb
▲▲											4409	4233	3869	3417	3164	2844	2668	2425		lb
10	▶	47	49	52	56	59	62	66	72	79	83	87	89	98	105	115	118	ft		
▲▲▲▲			8818	8311	7683	7132	6658	6239	5864	5225	4707	4409	4167	4079	3594	3318	2965	2866	lb	
▲▲▲											4409	4167	4079	3594	3318	2965	2866	lb		
▲▲											4409	4321	3825	3549	3197	3086		lb		
10	▶		52	56	59	62	66	72	75	82	85	89	92	ft						
▲▲▲▲			8818	8014	7485	7011	6592	5886	5578	5049	4828	4608	4409	lb						
▲▲▲												4409	lb							
▲▲												4409	lb							

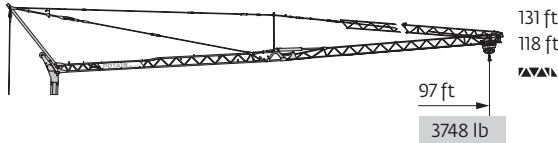

131 ft	10	▶	46	49	52	56	59	62	66	72	81	82	85	89	97	ft
▲▲▲▲			8818	8058	7441	6911	6449	6041	5677	5060	4409	4332	4167	3946	3527	lb
▲▲▲											4409	4332	4167	3946	3527	lb
▲▲											4409	4178	3748		lb	

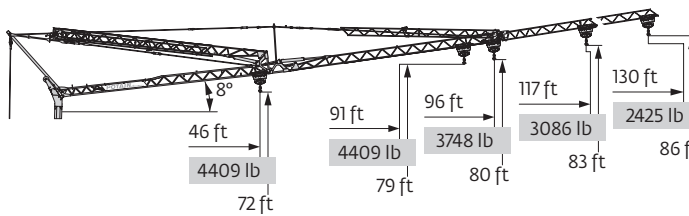

131 ft	10	▶	74	78	82	89	98	105	115	121	130	ft
▲▲▲▲			4409	4134	3924	3571	3131	2888	2579	2403	2205	lb
▲▲▲			4409	4189	3825	3373	3131	2811	2624	2425		lb
118 ft	10	▶		82	86	89	98	105	115	117	ft	
▲▲▲▲			4409	4167	4023	3549	3274	2932	2866	lb		
▲▲▲			4409	4266	3770	3494	3153	3086		lb		
92 ft	10	▶				91	ft					
▲▲▲▲						4409	lb					
▲▲▲						4409	lb					
131 ft	10	▶		80	84	89	96	ft				
▲▲▲▲			4409	4167	3902	3527	lb					
▲▲▲			4409	4123	3748	lb						
131 ft	10	▶	46	ft								
▲▲▲▲			4409	lb								
92 ft	10	▶	46	ft								
▲▲▲▲			4409	lb								

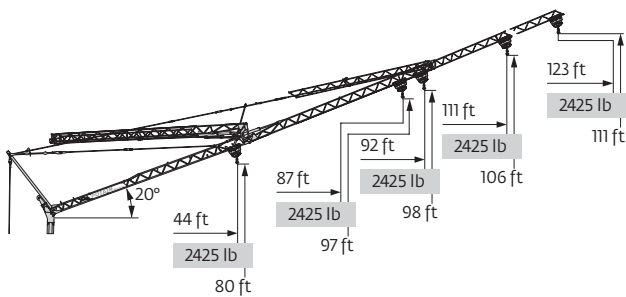

131 ft	10	▶									123	ft
▲▲▲▲											2205	lb
▲▲▲											2425	lb
118 ft	10	▶								111	ft	
▲▲▲▲										2205	lb	
▲▲▲										2425	lb	
92 ft	10	▶				87	ft					
▲▲▲▲						2205	lb					
▲▲▲						2425	lb					
131 ft	10	▶				92	ft					
▲▲▲▲						2205	lb					
▲▲▲						2425	lb					
131 ft	10	▶	44	ft								
▲▲▲▲			2205	lb								
92 ft	10	▶	44	ft								
▲▲▲▲			2425	lb								

Crane profile

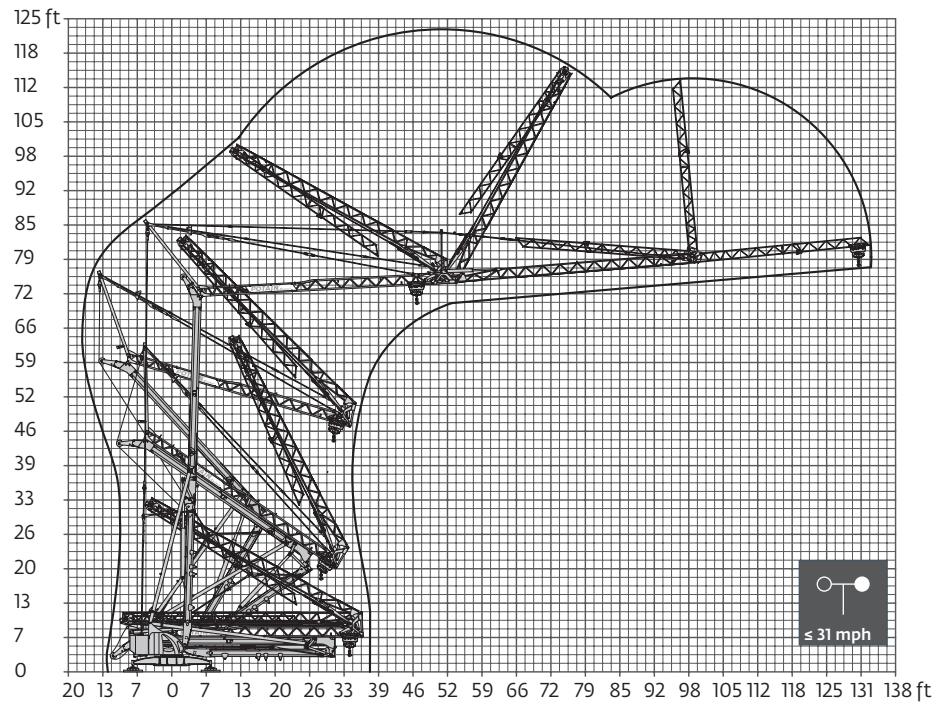

Igo 50: Raised jibs



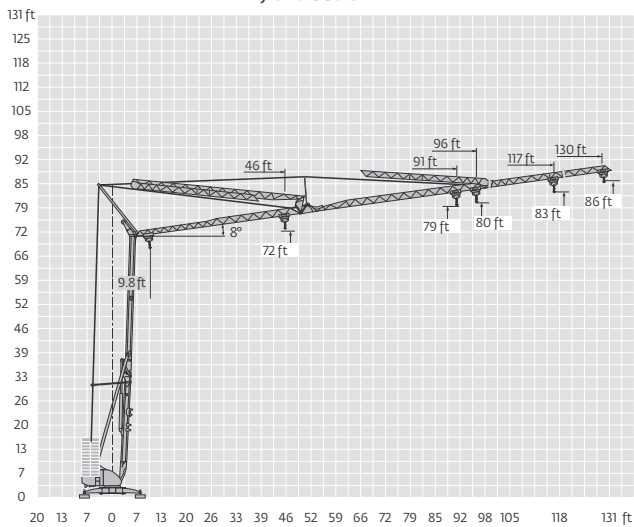

Jib raised 8°

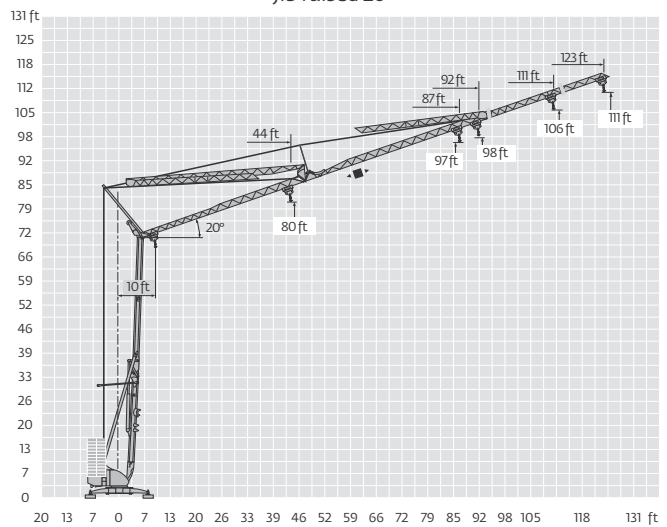





Jib raised 20°



Mechanisms

480 V - 60 Hz													hp	kW
	15 LVF 10 Optima	ft/min	12	59	102	167	218	6	30	51	84	108	15	11
		lb	4409	4409	4409	2205	1102	8818	8818	8818	4409	2205		
	3 DVF 5	ft/min	49 - 98 - 148 (0 → 2205 lb) 49 - 98 - 135 (2205 → 8818 lb)									3	2.2	
	RVF 51 Optima+	rpm	0 → 0.8									5.5	4	

 IEC 60204-32	 kVA
400 V (+10% -10%) 50 Hz / 480 V (+6% -10%) 60 Hz	 → 17 kVA  → 19 kVA

15 LVF 10 Optima

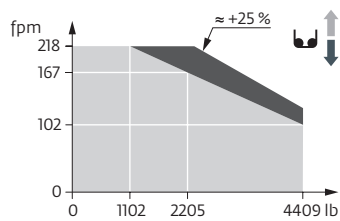

Metric dimensions

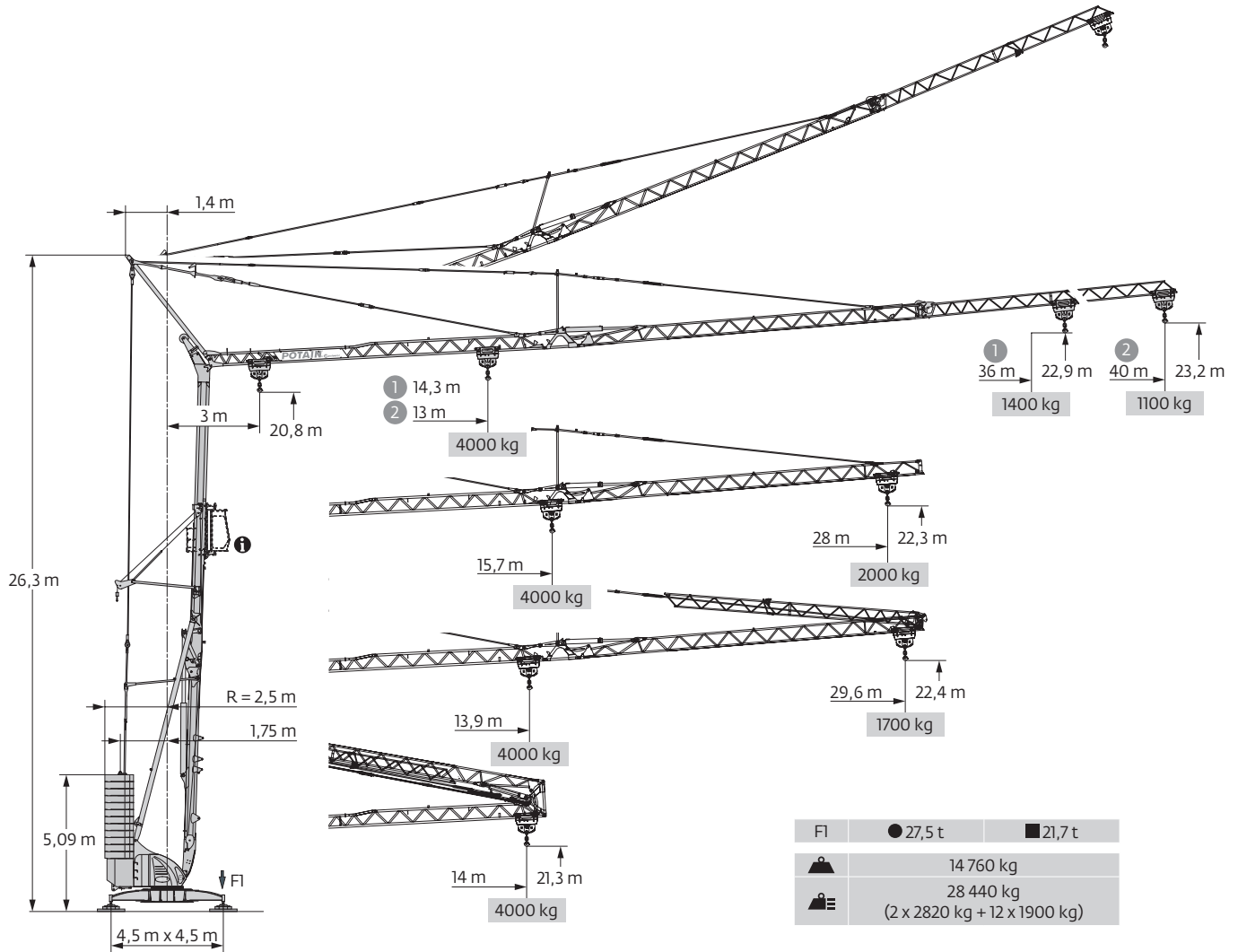

Metric crane profile

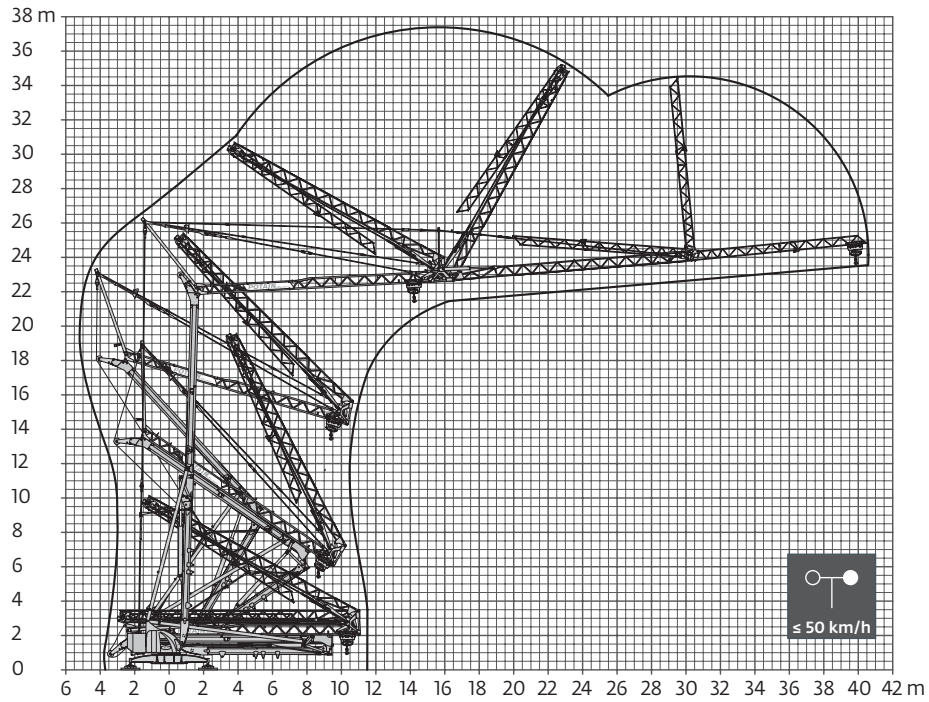

Igo 50: Raised jibs



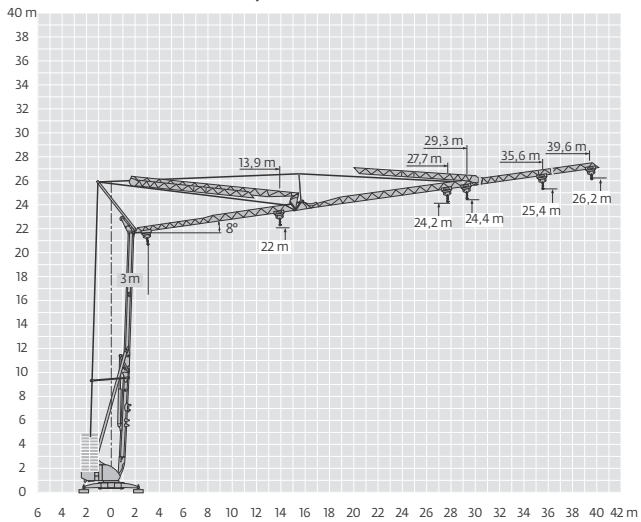

Jib raised 8°

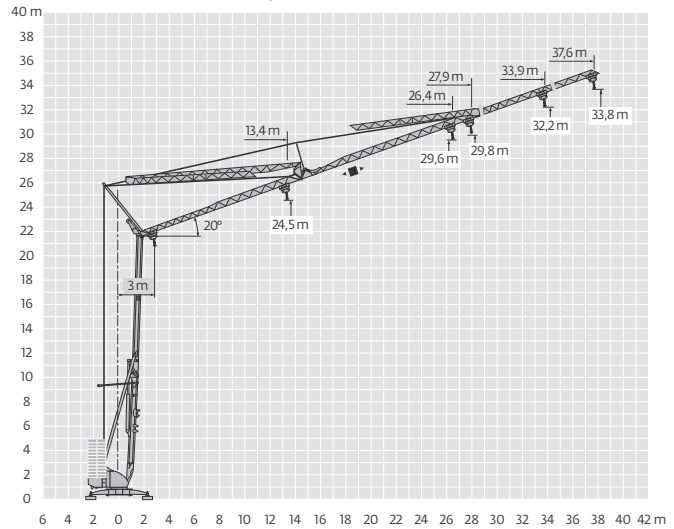





Jib raised 20°



Metric mechanisms

480 V - 60 Hz													hp	kW
	15 LVF 10 Optima	m/min	3,6	18	31	51	66,5	1,8	9	15,5	25,5	33	15	11
		kg	2000	2000	2000	1000	500	4000	4000	4000	2000	1000		
	3 DVF 5	m/min	15 - 30 - 45 (0 → 1000 kg) 15 - 30 - 41 (1000 → 4000 kg)									3	2,2	
	RVF 51 Optima+	rpm	0 → 0,8									5,5	4	

 IEC 60204-32	 kVA
400 V (+10% -10%) 50 Hz / 480 V (+6% -10%) 60 Hz	 → 17 kVA  → 19 kVA

15 LVF 10 Optima

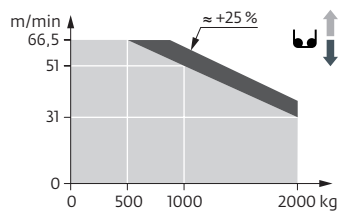

Symbols glossary



Anemometer



Hydraulic equipment



Reactions in service



Slewing



Ballast



Jib



Reactions out of service



Slewing radius



Chassis



Mast



Reeving



Standard equipment



Consult us



Optional hydraulic ballasting derrick



Reeving 2-part



Total ballast weight



Controls



Optional transport axle sets



Reeving 4-part



Trolleying



Electrical equipment



Options



Required power



Weight without load, without ballast, without transport axles, with max. jib and standard height



Hoisting

Manitowoc Cranes

Regional headquarters

Americas

Manitowoc, Wisconsin, USA

Tel: +1 920 684 6621

Fax: +1 920 683 6277

Shady Grove, Pennsylvania, USA

Tel: +1 717 597 8121

Fax: +1 717 597 4062

Europe, Middle East, Africa

Dardilly, France

Tel: +33 (0)4 72 18 20 20

Fax: +33 (0)4 72 18 20 00

China

Shanghai, China

Tel: +86 21 6457 0066

Fax: +86 21 6457 4955

Greater Asia-Pacific

Singapore

Tel: +65 6264 1188

Fax: +65 6862 4040

Regional offices

Americas

Brazil

Alphaville

Mexico

Monterrey

Chile

Santiago

Europe, Middle East,

Africa

France

Baudemont

Cergy

Decines

Germany

Langenfeld

Italy

Lainate

Netherlands

Breda

Poland

Warsaw

Portugal

Baltar

Russia

Moscow

South Africa

Johannesburg

U.A.E.

Dubai

U.K.

Buckingham

China

Beijing

Chengdu

Guangzhou

Xian

Greater Asia-Pacific

Australia

Brisbane

Melbourne

Sydney

India

Chennai

Delhi

Hyderabad

Pune

Korea

Seoul

Philippines

Makati City

Singapore

Factories

Brazil

Passo Fundo

China

TaiAn

Zhangjiagang

France

Charlieu

Moulins

Germany

Wilhelmshaven

India

Pune

Italy

Niella Tanaro

Portugal

Baltar

Fânzeres

USA

Manitowoc

Port Washington

Shady Grove

This document is non-contractual. Constant improvement and engineering progress make it necessary that we reserve the right to make specification, equipment, and price changes without notice. Illustrations shown may include optional equipment and accessories and may not include all standard equipment.